

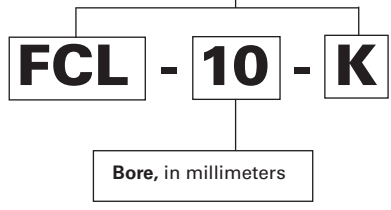

Drawn Cup Roller Clutches

Metric Series	
FCS, FC-K	regular clutch, single roller per stainless steel spring
FC	regular clutch, multi-roller per stainless steel spring
FCL-K	light series clutch, single roller per stainless steel spring
FCB	regular clutch and bearing assembly, multi-roller per stainless steel spring
FCBL-K, FCBN-K	light series clutch and bearing assembly, single roller per stainless steel spring



Inch Series	
RC	regular clutch, single roller per integral spring
RC-FS	regular clutch, single roller per stainless steel spring
RCB	regular clutch and bearing assembly, single roller per integral spring
RCB-FS	regular clutch and bearing assembly, single roller per stainless steel spring

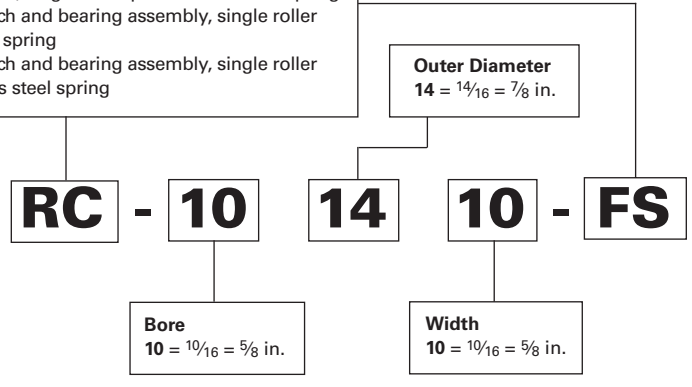



DRAWN CUP ROLLER CLUTCHES METRIC AND INCH SERIES

Drawn cup roller clutch transmits torque between shaft and housing in one direction and allows free overrun in the opposite direction. When transmitting torque, either the shaft or the housing can be the input member. Applications are generally described as indexing, backstopping or overrunning.

B

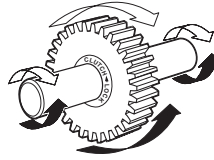

Fig. B-18.
Lock function: shaft drives gear clockwise (white arrows) or gear can drive shaft counterclockwise (black arrows)

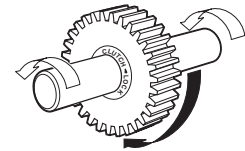

Fig. B-19.
Overrun function: shaft overruns in gear counterclockwise (white arrows) or gear overruns on shaft clockwise (black arrow)

IDENTIFICATION

The prefix letters in the designation of the drawn cup roller clutches and drawn cup roller clutch and bearing assemblies denote whether these are manufactured to metric or inch nominal dimensions. Designation codes for clutches and clutch and bearing assemblies with metric nominal dimensions begin with the letter "F." Designation codes for clutches and clutch and bearing assemblies with inch nominal dimensions begin with the letter "R."

The basic types of clutches and clutch and bearing assemblies are listed below:

METRIC SERIES TYPES

- FCS, FC-K** Regular clutch, single roller per stainless steel spring.
- FC** Regular clutch, multi-roller per stainless steel spring.
- FCB** Regular clutch and bearing assembly, multi-roller per stainless steel spring.
- FCL-K** Light series clutch, single roller per stainless steel spring.
- FCBL-K, FCBN-K** Light series clutch and bearing assembly. Single roller per stainless steel spring.

INCH SERIES TYPES

- RC** Regular clutch, single roller per integral spring.
- RC-FS** Regular clutch, single roller per stainless steel spring.
- RCB** Regular clutch and bearing assembly, single roller per integral spring.
- RCB-FS** Regular clutch and bearing assembly, single roller per stainless steel spring.



Drawn cup roller clutch type FC with stainless steel springs



Drawn cup clutch and bearing assembly type FCB with stainless steel springs



Drawn cup roller clutch, types FCS, FC-K, FCL-K, and RC-FS with stainless steel springs

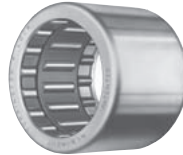

Drawn cup clutch and bearing assembly types FCBL-K, FCBN-K and RCB-FS with stainless steel springs



Drawn cup roller clutch, type RC with integral springs



Drawn cup clutch and bearing assembly type RCB with integral springs

Fig. B-20. Types of clutches and clutch and bearing assemblies

CONSTRUCTION

In many respects, construction is similar to that of drawn cup bearings. Design and manufacture of drawn cup clutches – just as with drawn cup bearings – was pioneered and developed by The Torrington Company. The well-established design utilizes the same low-profile radial section as drawn cup bearings. The precisely formed interior ramps provide surfaces against which the needle rollers wedge. These positively lock the clutch with the shaft when rotated in the proper direction. These ramps, formed during the operation of drawing the cup, are case hardened for wear resistance. The incorporation of ramp forming into the cup drawing operation is a manufacturing innovation that contributes to the low cost of the unit.

Two designs of precision molded clutch cages are employed. Clutch and clutch and bearing assembly types – FC, FC-K, FCS, FCL-K, RC-FS, FCB, FCBN-K, FCBL-K and RCB-FS – use a glass fiber, reinforced nylon cage, equipped with inserted stainless steel leaf springs. The stainless steel springs permit higher rates of clutch engagement and achieve greater spring life. The nylon cage permits operation at higher temperatures. Clutch types RC and RCB utilize a one-piece cage of acetyl resin polymer with integral leaf style springs. They are used for lower temperatures than permitted for the units with nylon cages.

Types FCB, FCBL-K, FCBN-K, RCB and RCB-FS clutch and bearing assemblies have cages, for retention and guidance of the needle rollers in the bearings, located on both sides of the clutch unit.



Fig. B-21. Clutch and bearing assembly

Types FC, FC-K, FCS, FCL-K, RC and RC-FS are of clutch-only configurations for use with external radial support (usually two drawn cup needle roller bearings). Separate bearings position the shaft and housing concentrically and carry the radial load during overrun.



Fig. B-22. Clutch only

OPERATION

Operation is in two modes: the overrun mode and the lock mode. Operational mode is controlled by the direction of the clutch or shaft rotation with respect to the locking ramps.

In the overrun mode, shown in the drawings below, the relative rotation between the housed clutch and the shaft causes the rollers to move away from their locking position against the locking ramps in the drawn cup. The housing and the clutch are then free to overrun in one direction, or the shaft is free to overrun in the other direction.

In the lock mode, shown in the drawings below, the relative rotation between the housed clutch and the shaft is opposite to that in the overrun mode. The rollers, assisted by the leaf-type springs, become wedged between the locking ramps and the shaft to transmit torque between the two members. Either the member housing the clutch drives the shaft in one direction, or the shaft can drive the clutch and its housing member in the other direction.

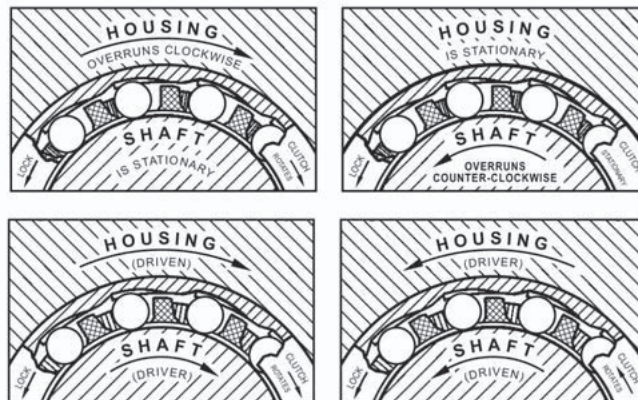

Clearance between the rollers and cup ramps is exaggerated in these drawings.

Fig. B-23. Overrun mode and lock mode



DRAWN CUP ROLLER CLUTCHES

METRIC SERIES

B

- For proper application, separate bearings are suggested (adjacent to clutch) to carry radial loads and assure concentricity between shaft and housing.
- The clutch engages when housing is rotated relative to the shaft in direction of arrow marking (← LOCK), as labeled on cup.
- Proper inspection requires use of ring gage and bore plug gage(s). See the inspection section on page B-133.
- Full details on installation are given on page B-132.
- Shaft raceway and housing bore diameters that are necessary for proper mounting and operation are listed on the opposite page.
- Types FC, FCS, FC-K and FCL-K clutches have stainless steel springs inserted in molded cage to position rollers for lockup.



The mounted clutch and bearing assembly engages when the housing is rotated relative to the shaft in the direction of the arrow marking (← LOCK) stamped on the cup.

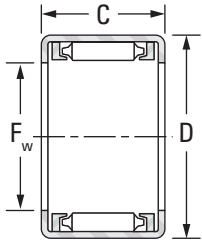

FC

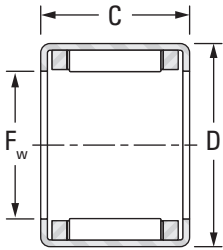

FCS, FCL-K and FC-K

Shaft Diameter	F _w	D	C	Clutch Designation	Torque Rating	Z		Suitable Drawn Cup Bearing ⁽¹⁾
						Minimum O.D. of Steel Housing for Rated Torque	Overrun Limiting Speed Rating for Rotating Shaft	
mm in.	mm in.	mm in.	mm in.		N-m lbf-in.	mm in.	min ⁻¹	
4 0.1575	4 0.1575	8 0.3150	6 0.236	FC-4-K	0.349 3.09	11 0.433	26000	HK0408
6 0.2362	6 0.2362	10 0.3937	12 0.472	FCS-6	2.15 19.0	14 0.551	22000	HK0608
	6 0.2362	10 0.3937	12 0.472	FC-6	2.63 23.3	14 0.551	22000	HK0608
8 0.3150	8 0.3150	12 0.4724	12 0.472	FCL-8-K	3.39 30.0	17 0.669	21000	HK0808
	8 0.3150	14 0.5512	12 0.472	FC-8	4.42 39.1	20 0.787	21000	—
10 0.3937	10 0.3937	14 0.5512	12 0.472	FCL-10-K	4.60 40.7	20 0.787	19000	HK1010
	10 0.3937	16 0.6299	12 0.472	FC-10	5.82 51.5	25 0.984	19000	—
12 0.4724	12 0.4724	18 0.7087	16 0.630	FC-12	14.0 124	27 1.063	19000	HK1212
14 0.5512	14 0.5512	20 0.7874	16 0.630	FC-14-K	14.8 131	29 1.142	16000	HK1412
16 0.6299	16 0.6299	22 0.8661	16 0.630	FC-16	21.7 192	31 1.22	14000	HK1612
20 0.7874	20 0.7874	26 1.0236	16 0.630	FC-20	32.6 289	38 1.496	11000	HK2012
	20 0.7874	26 1.0236	16 0.630	FC-20-K	30.0 266	38 1.496	11000	HK2012
25 0.9843	25 0.9843	32 1.2598	20 0.787	FC-25-K	66.4 588	46 1.811	8700	HK2512
	25 0.9843	32 1.2598	20 0.787	FC-25	71.0 628	46 1.811	8700	HK2512
30 1.1811	30 1.1811	37 1.4567	20 0.787	FC-30	99.1 877	51 2.008	7300	HK3012
35 1.3780	35 1.3780	42 1.6535	20 0.787	FCS-35	107.0 947	56 2.205	6100	HK3512

⁽¹⁾ See pages B-52 to B-61 for suitable bearing types and sizes.

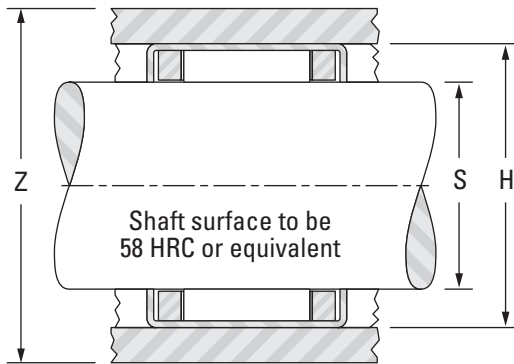

Gaging			S		H		Approx. Wt.
Ring Gage	Clutch Locking Plug	Clutch Overrun Plug	Shaft Raceway Diameter		Housing Bore		
			Mounting				
			Max.	Min.	Max.	Min.	
mm in.	mm in.	mm in.	mm in.	mm in.	mm in.	kg lbs.	
7.984 0.3143	3.980 0.1567	4.004 0.1576	4.000 0.1575	3.995 0.1573	7.993 0.3147	7.984 0.3143	0.001 0.002
9.984 0.3931	5.980 0.2354	6.004 0.2364	6.000 0.2362	5.995 0.2360	9.993 0.3934	9.984 0.3931	0.003 0.007
9.984 0.3931	5.980 0.2354	6.004 0.2364	6.000 0.2362	5.995 0.2360	9.993 0.3934	9.984 0.3931	0.004 0.009
11.980 0.4717	7.976 0.3140	8.005 0.3152	8.000 0.3150	7.994 0.3147	11.991 0.4721	11.980 0.4717	0.003 0.007
13.980 0.5504	7.976 0.3140	8.005 0.3152	8.000 0.3150	7.994 0.3147	13.991 0.5508	13.980 0.5504	0.007 0.015
13.980 0.5504	9.976 0.3928	10.005 0.3939	10.000 0.3937	9.994 0.3935	13.991 0.5508	13.980 0.5504	0.004 0.009
15.980 0.6291	9.976 0.3928	10.005 0.3939	10.000 0.3937	9.994 0.3935	15.991 0.6296	15.980 0.6291	0.009 0.020
17.980 0.7079	11.974 0.4714	12.006 0.4727	12.000 0.4724	11.992 0.4721	17.991 0.7083	17.980 0.7079	0.012 0.026
19.976 0.7865	13.972 0.5501	14.006 0.5514	14.000 0.5512	13.992 0.5509	19.989 0.7870	19.976 0.7865	0.016 0.035
21.976 0.8652	15.972 0.6288	16.006 0.6302	16.000 0.6299	15.992 0.6296	21.989 0.8657	21.976 0.8652	0.018 0.040
25.976 1.0227	19.970 0.7862	20.007 0.7877	20.000 0.7874	19.991 0.7870	25.989 1.0232	25.976 1.0227	0.021 0.046
25.976 1.0227	19.970 0.7862	20.007 0.7877	20.000 0.7874	19.991 0.7870	25.989 1.0232	25.976 1.0227	0.016 0.035
31.972 1.2587	24.967 0.9830	25.007 0.9845	25.000 0.9843	24.991 0.9839	31.988 1.2594	31.972 1.2587	0.026 0.057
31.972 1.2587	24.967 0.9830	25.007 0.9845	25.000 0.9843	24.991 0.9839	31.988 1.2594	31.972 1.2587	0.034 0.075
36.972 1.4556	29.967 1.1798	30.007 1.1814	30.000 1.1811	29.991 1.1807	36.988 1.4562	36.972 1.4556	0.042 0.093
41.972 1.6524	34.964 1.3765	34.009 1.3389	35.000 1.3780	34.989 1.3775	41.988 1.6531	41.972 1.6524	0.048 0.106





DRAWN CUP ROLLER CLUTCHES AND BEARING ASSEMBLIES
METRIC SERIES

B

- The clutch and bearing assembly engages when the housing is rotated relative to shaft in direction of arrow marking (← LOCK), as labeled on cup.
- Shaft raceway and housing bore diameters that are necessary for proper mounting and operation are listed on the opposite page.
- Proper inspection requires use of ring gage and bore plug gage(s). See the inspection section on page B-133.

- Full details on installation are given on page B-132.
- Types FCB, FCBL-L and FCBN-K clutch and bearing assemblies have stainless steel springs inserted in molded cage to position rollers for lockup.



The mounted clutch and bearing assembly engages when the housing is rotated relative to the shaft in the direction of the arrow marking (← LOCK) stamped on the cup.

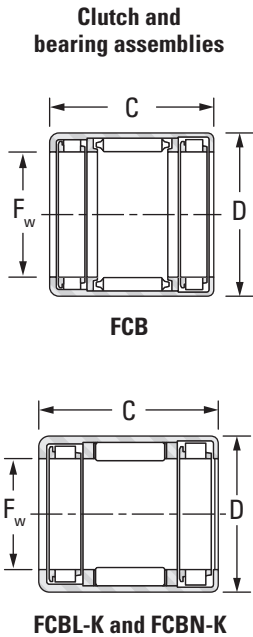

Shaft Diameter	F _w	D	C -0.30 mm -0.012 in.	Clutch and Bearing Assembly Designation	Torque Rating	Z Minimum O.D. of Steel Housing for Rated Torque	Load Ratings ⁽¹⁾		Overrun Limiting Speed Rating for Rotating Shaft
							C		
							Dynamic	C ₀ Static	
mm in.	mm in.	mm in.	mm in.		N-m lbf-in.		kN lbf.	kN lbf.	min ⁻¹
4 0.1575	4 0.1575	10 0.3937	9 0.354	FCBN-4-K	0.19 1.68	16 0.630	1.86 418	0.99 223	26000
6 0.2362	6 0.2362	12 0.4724	10 0.394	FCBN-6-K	0.56 4.96	18 0.709	2.48 558	1.48 333	22000
8 0.3150	8 0.3150	12 0.4724	22 0.866	FCBL-8-K	3.39 30.0	17 0.669	3.62 814	3.28 737	21000
	8 0.3150	14 0.5512	20 0.787	FCB-8	4.42 39.1	20 0.787	4.22 949	3.04 683	21000
10 0.3937	10 0.3937	16 0.6299	20 0.787	FCB-10	5.82 51.5	25 0.984	4.84 1090	3.80 854	19000
12 0.4724	12 0.4724	18 0.7087	26 1.024	FCB-12	14.0 124	27 1.063	6.30 1420	5.84 1310	19000
16 0.6299	16 0.6299	22 0.8661	26 1.024	FCB-16	21.7 192	31 1.220	6.64 1490	7.12 1600	14000
20 0.7874	20 0.7874	26 1.0236	26 1.024	FCB-20	32.6 289	38 1.496	8.16 1830	9.46 2130	11000
25 0.9843	25 0.9843	32 1.2598	30 1.181	FCB-25	71.0 628	46 1.811	11.3 2540	13.1 2940	8700
30 1.1811	30 1.1811	37 1.4567	30 1.181	FCB-30	99.1 877	51 2.008	11.5 2590	14.9 3350	7300

⁽¹⁾ Load ratings are based on a minimum raceway hardness of 58 HRC or equivalent.

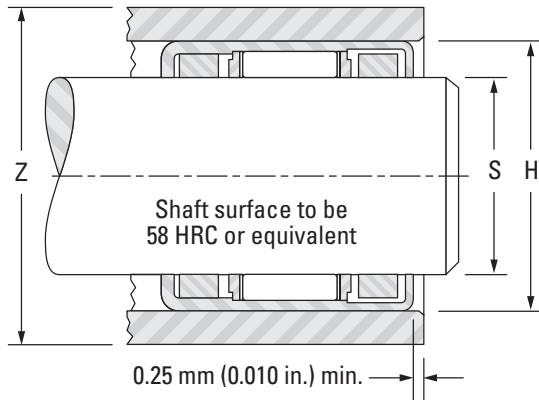

Gaging				S		H		Approx. Wt.
Ring Gage	Clutch Locking Plug	Clutch Overrun and Bearing Go Plug	Bearing No Go Plug	Mounting				
				Max.	Min.	Max.	Min.	
mm in.	mm in.	mm in.	mm in.	mm in.	mm in.	mm in.	mm in.	kg lbs.
9.984 0.3931	3.980 0.1567	4.004 0.1576	4.030 0.1587	4.000 0.1575	3.995 0.1573	9.993 0.3934	9.984 0.3931	0.003 0.007
11.980 0.4717	5.977 0.2353	6.004 0.2364	6.030 0.2374	6.000 0.2362	5.995 0.2360	11.991 0.4721	11.980 0.4717	0.004 0.009
11.980 0.4717	7.976 0.3140	8.005 0.3152	8.033 0.3163	8.000 0.3150	7.994 0.3147	11.991 0.4721	11.980 0.4717	0.005 0.011
13.980 0.5504	7.976 0.3140	8.005 0.3152	8.033 0.3163	8.000 0.3150	7.994 0.3147	13.991 0.5508	13.980 0.5504	0.011 0.024
15.980 0.6291	9.976 0.3928	10.005 0.3939	10.033 0.3950	10.000 0.3937	9.994 0.3935	15.991 0.6296	15.980 0.6291	0.013 0.029
17.980 0.7079	11.974 0.4714	12.006 0.4727	12.036 0.4739	12.000 0.4724	11.992 0.4721	17.991 0.7083	17.980 0.7079	0.018 0.040
21.976 0.8652	15.972 0.6288	16.006 0.6302	16.036 0.6313	16.000 0.6299	15.992 0.6296	21.989 0.8657	21.976 0.8652	0.024 0.053
25.976 1.0227	19.970 0.7862	20.007 0.7877	20.043 0.7891	20.000 0.7874	19.991 0.7870	25.989 1.0232	25.976 1.0227	0.028 0.062
31.972 1.2587	24.967 0.9830	25.007 0.9845	25.043 0.9859	25.000 0.9843	24.991 0.9839	31.988 1.2594	31.972 1.2587	0.048 0.106
36.972 1.4556	29.967 1.1798	30.007 1.1814	30.043 1.1828	30.000 1.1811	29.991 1.1807	36.988 1.4562	36.972 1.4556	0.054 0.119

B

